

# 52E

Quadro Elettrico 52E  
Control Panel 52E

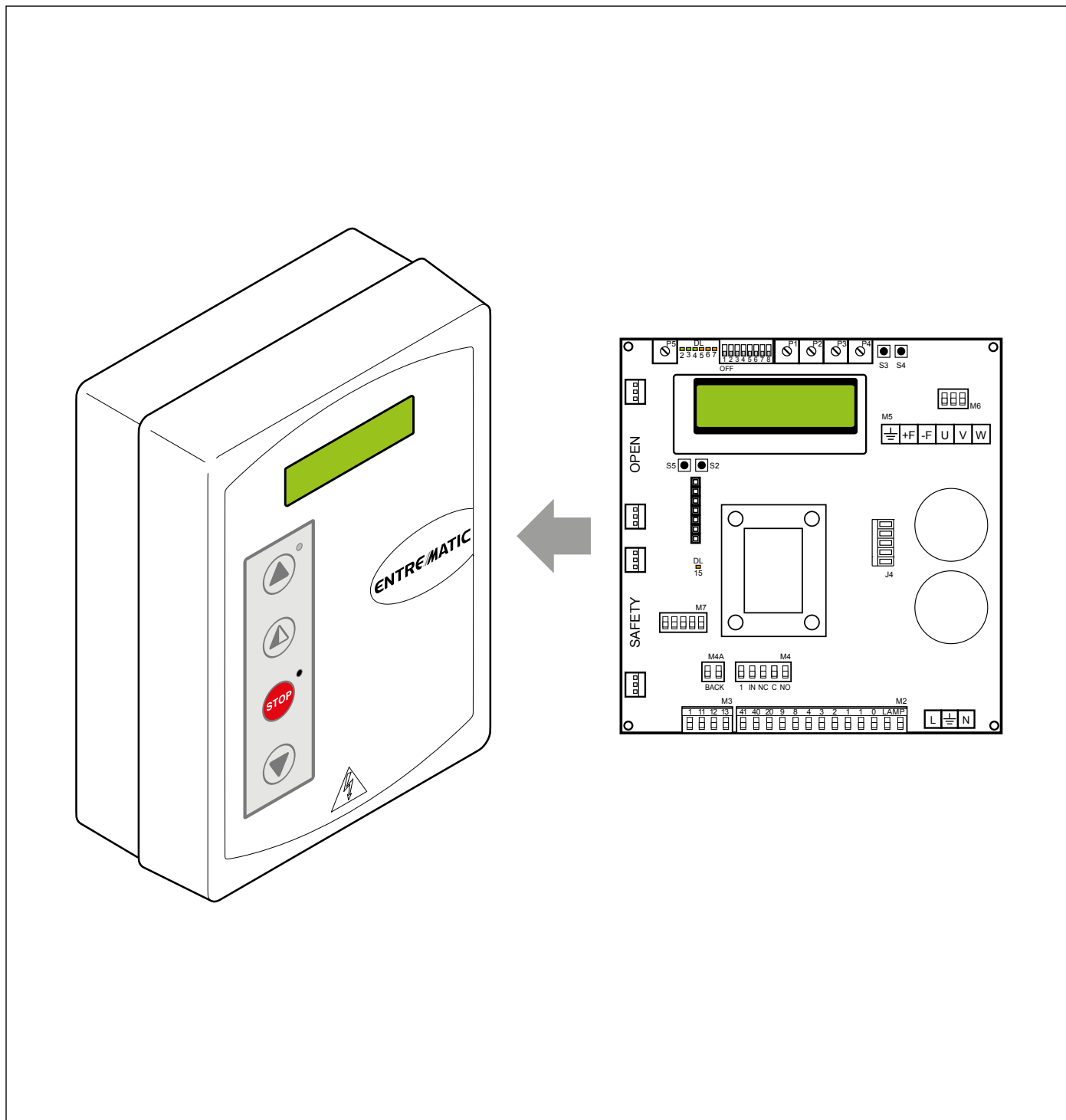

ODT866  
rev. 2016-01-25

## Manuale installazione quadro 52E

Con motori K22INV e K10INV con Finecorsa dotati di microinterruttori

## Installation manual for 52E control panel

with K22INV and K10INV motors, with limit switches group

IT

EN

## INDICE

Cap.	Argomento .....	Pag.
1.	<b>COLLEGAMENTI</b> .....	3
2.	<b>REGOLAZIONI E SETTAGGI</b> .....	4
3.	<b>COLLAGAMENTI ELETTRICI</b>	
	Smart Reset .....	5
	Sector Reset .....	6
	Smart Plus .....	7
	Sector Plus .....	8
	Traffic C .....	9
4.	<b>REGOLAZIONE FINECORSA</b> .....	10
5.	<b>RICERCA GUASTI</b> .....	10
6.	<b>PROGRAMMAZIONE</b>	
	Menu di Installazione .....	11
	Menu avanzato .....	12
	Menù Service .....	13
7.	<b>ALLARMI</b> .....	14
8.	<b>INTERBLOCCO</b> .....	14

## 1. AVVERTENZE GENERALI PER LA SICUREZZA

 Il presente manuale di installazione è rivolto esclusivamente a personale professionalmente competente. L'installazione, i collegamenti elettrici e le regolazioni devono essere effettuati nell'osservanza della Buona Tecnica e in ottemperanza alle norme vigenti.

Leggere attentamente le istruzioni prima di iniziare l'installazione del prodotto. Una errata installazione può essere fonte di pericolo. I materiali dell'imballaggio (plastica, polistirolo, ecc.) non vanno dispersi nell'ambiente e non devono essere lasciati alla portata dei bambini in quanto potenziali fonti di pericolo.

Prima di iniziare l'installazione verificare l'integrità del prodotto. Non installare il prodotto in ambiente e atmosfera esplosivi: presenza di gas o fumi infiammabili costituiscono un grave pericolo per la sicurezza. Prima di installare la porta, apportare tutte le modifiche strutturali relative alla realizzazione dei franchi di sicurezza ed alla protezione o segregazione di tutte le zone di schiacciamento, cesoiamento, convogliamento e di pericolo in genere.

Verificare che la struttura esistente abbia i necessari requisiti di robustezza e stabilità. I dispositivi di sicurezza (fotocellule, coste sensibili, arresto di emergenza, ecc.) devono essere installati tenendo in considerazione: le normative e le direttive in vigore, i criteri della Buona Tecnica, l'ambiente di installazione, la logica di funzionamento del sistema e le forze sviluppate dalla porta o cancello motorizzati.

I dispositivi di sicurezza devono proteggere eventuali zone di schiacciamento, cesoiamento, convogliamento e di pericolo in genere, della porta. Applicare le segnalazioni previste dalle norme vigenti per individuare le zone pericolose.

Ogni installazione deve avere visibile l'indicazione dei dati identificativi della porta.

 Prima di collegare l'alimentazione elettrica accertarsi che i dati di targa siano rispondenti a quelli della rete di distribuzione elettrica. Prevedere sulla rete di alimentazione un interruttore/sezionatore onnipolare con distanza d'apertura dei contatti uguale o superiore a 3 mm. Verificare che a monte dell'impianto elettrico vi sia un interruttore differenziale e una protezione di sovracorrente adeguati. Collegare la porta ad un efficace impianto di messa a terra eseguito come previsto dalle vigenti norme di sicurezza. Il costruttore della porta declina ogni responsabilità qualora vengano installati componenti incompatibili ai fini della sicurezza e del buon funzionamento o qualora vengano effettuate modifiche di qualsiasi natura senza la specifica autorizzazione del costruttore stesso. Per l'eventuale riparazione o sostituzione dei prodotti dovranno essere utilizzati esclusivamente ricambi originali Entrematic Group AB. L'installatore deve fornire tutte le informazioni relative al funzionamento automatico, manuale e di emergenza della porta o cancello motorizzati, e consegnare all'utilizzatore dell'impianto le istruzioni d'uso.











 **Accessorio opzionale**

 **Safety Confort**

 **Safety Top**

### Tutti i diritti sono riservati

I dati riportati sono stati redatti e controllati con la massima cura. Tuttavia non possiamo assumerci alcuna responsabilità per eventuali errori, omissioni o approssimazioni dovute ad esigenze tecniche o grafiche.





INGRESSI			
Comando		Funzione	Descrizione
1	 2	N.C. STOP	Se su menu programmazione (pag.15 punto 16) Contatto 1-2 abilitato, l'apertura del contatto implica lo STOP della porta
1	 3	N.O. Apertura	La chiusura del contatto attiva la manovra di apertura.
1	 4	N.O. Chiusura	La chiusura del contatto attiva la manovra di chiusura.
41	 40	N.C. Sicurezza di inversione	L'apertura del contatto di sicurezza provoca l'inversione del movimento (riapertura) durante la fase di chiusura.
1	 8	N.C. Sicurezza di inversione	L'apertura del contatto di sicurezza provoca l'inversione del movimento (riapertura) durante la fase di chiusura.
1	 20	N.O. Apertura parziale	La chiusura del contatto attiva una manovra di apertura parziale della durata impostata mediante il menu avanzato.
1	 11	N.C. Finecorsa chiusura	L'apertura del contatto arresta il movimento di chiusura.
1	 13	N.C. Finecorsa apertura	L'apertura del contatto arresta il movimento di apertura.
1	 12	N.C. Finecorsa rallentamento	L'apertura del contatto attiva il rallentamento in apertura.
1	 9	N.O. Abilitazione chiusura con SLEC	In caso di porte con SLEC, l'apertura del contatto permette il funzionamento della porta solo a uomo presente.





### CONNETTORI BORDO QUADRO

M2	Sicurezza / Comandi
M3	Segnale posizione
M4	Interblocco
M4A	Back
M5	Motore / Freno motore

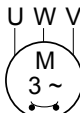
J4	Resistenza di frenatura
OPEN	Scheda ausiliaria quadro
SAFETY	Scheda ausiliaria sicurezza

### USCITE

Uscita	Valore	Descrizione
1  + 0  -	24 V = / 0,5 A	<b>Alimentazione accessori.</b> Uscita per alimentazione accessori esterni comprese lampade stato automazione.
 LAMP	230 V~ / 50 W	<b>Lampeggiante (LAMP).</b> Si attiva durante le manovre di apertura e chiusura.
-F  +F	200 V = / 0,2 A o 24 V = / 0,5 A	<b>Elettrofreno motore.</b> Settato automaticamente con la scelta del modello porta nel menu programmazione. L'uscita è attiva per tutta la durata del movimento sia in apertura che in chiusura.
	230 V~ / 6 A	<b>Motore trifase.</b>

Trimmer	Descrizione
P1 	Velocità apertura
P2 	Velocità chiusura
P3 	Decelerazione in apertura
P4 	Regolazione decelerazione in chiusura
P5 	Regolazione contrasto display.

Dip - switch	Descrizione	OFF	ON
DIP 1	Uso futuro	–	–
DIP 2	Accesso a menu avanzato	Disabilitato.	Abilitato.
DIP 3	Abilitazione trimmers	Disabilitato.	Abilitato.
DIP 4	Contatore TOT: Numero manovre SVC: Manovre mancanti a service	Disabilitato.	Abilitato.
DIP 5	Accesso menu service	Disabilitato.	Abilitato.
DIP 6	Visualizzatore dati funzionamento porta ( F. Lavoro, I. Bus, I. Picco, V. Bus )	Disabilitato.	Abilitato.
DIP 7	Uso futuro	–	–
DIP 8	Uso futuro	–	–

LED	Acceso
DL2	Posizione chiusura
DL3	Rallentamento
DL6	Apertura Parziale
DL7	Posizione apertura
DL15	Autostart

Pulsanti	Descrizione
S2	USATO PER PROGRAMMAZIONE
S3	NON USATO
S4	NON USATO
S5	USATO PER PROGRAMMAZIONE

	Funzionamento Standard		Funzionamento Programmazione
	Pulsante	LED	Pulsante
	Attiva la manovra di apertura.	- Il led verde acceso segnala la presenza di alimentazione 24 V=.	Scorrimento menu
	Attiva la manovra di apertura parziale.		Conferma
	Attiva e disattiva la funzione di STOP.	- Il led rosso acceso segnala l'attivazione dello STOP. - Il led rosso lampeggiante segnala l'attivazione delle sicurezze. - Il led rosso con lampeggio breve segnala il raggiungimento della soglia di servizio	
	Attiva la manovra di chiusura.		Scorrimento menu

**! Dip 3 ON**

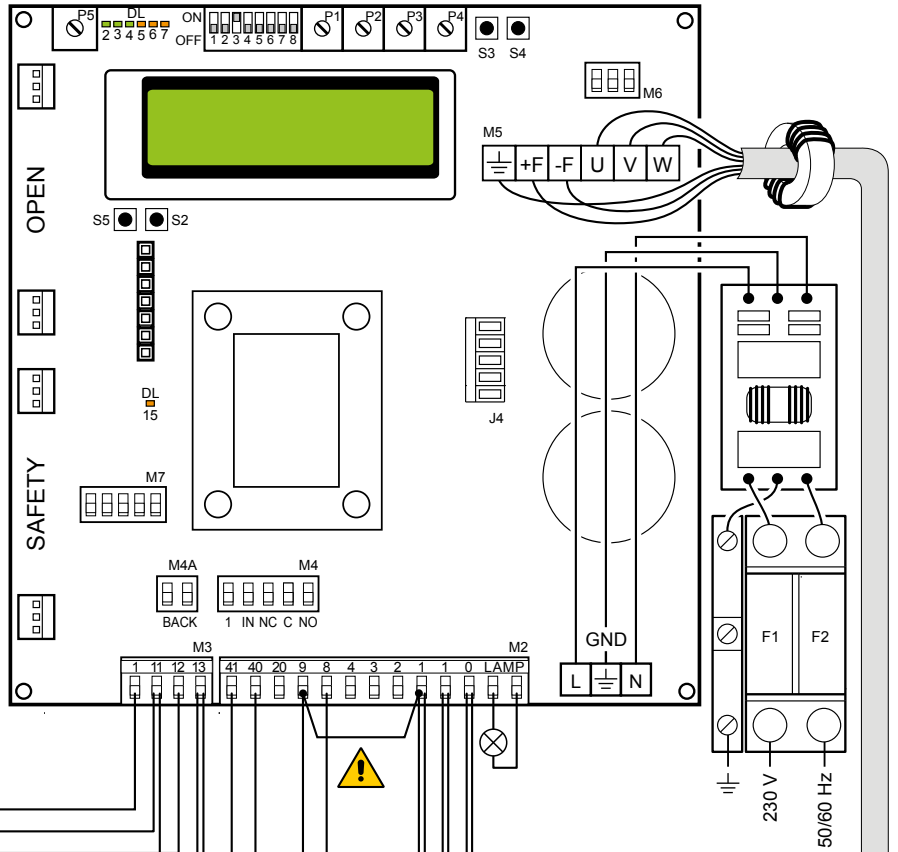
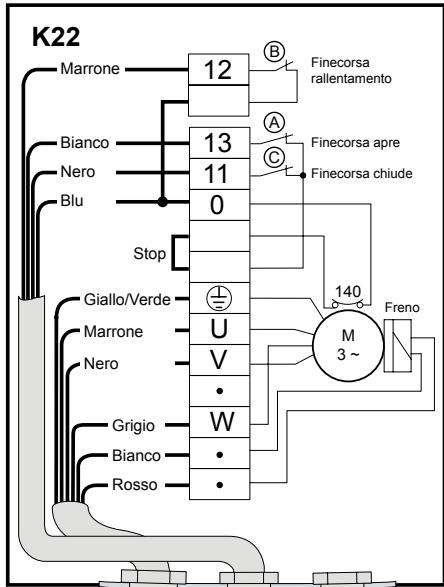

**! 1-9 Chiudere per abilitare chiusura porta**

**! Dip 1 OFF  
Dip 2,3,4 ON**

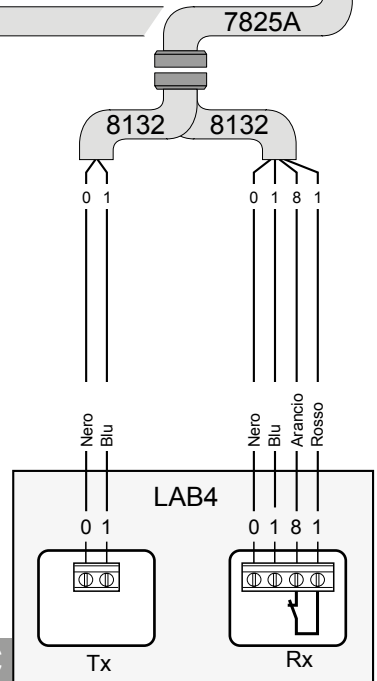
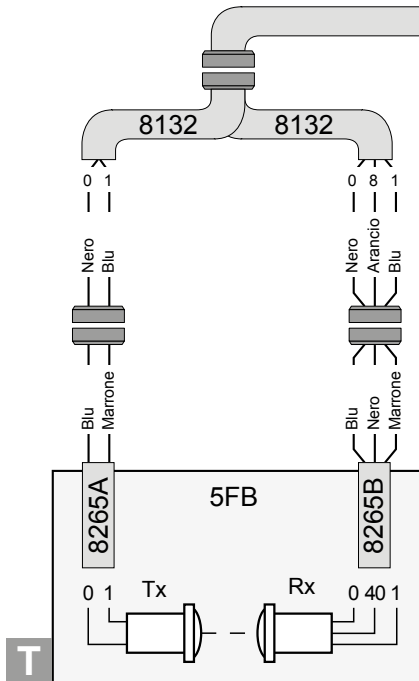
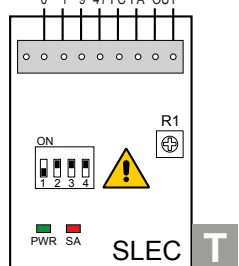

7978

# SECTOR RESET

**! Dip 3 ON**

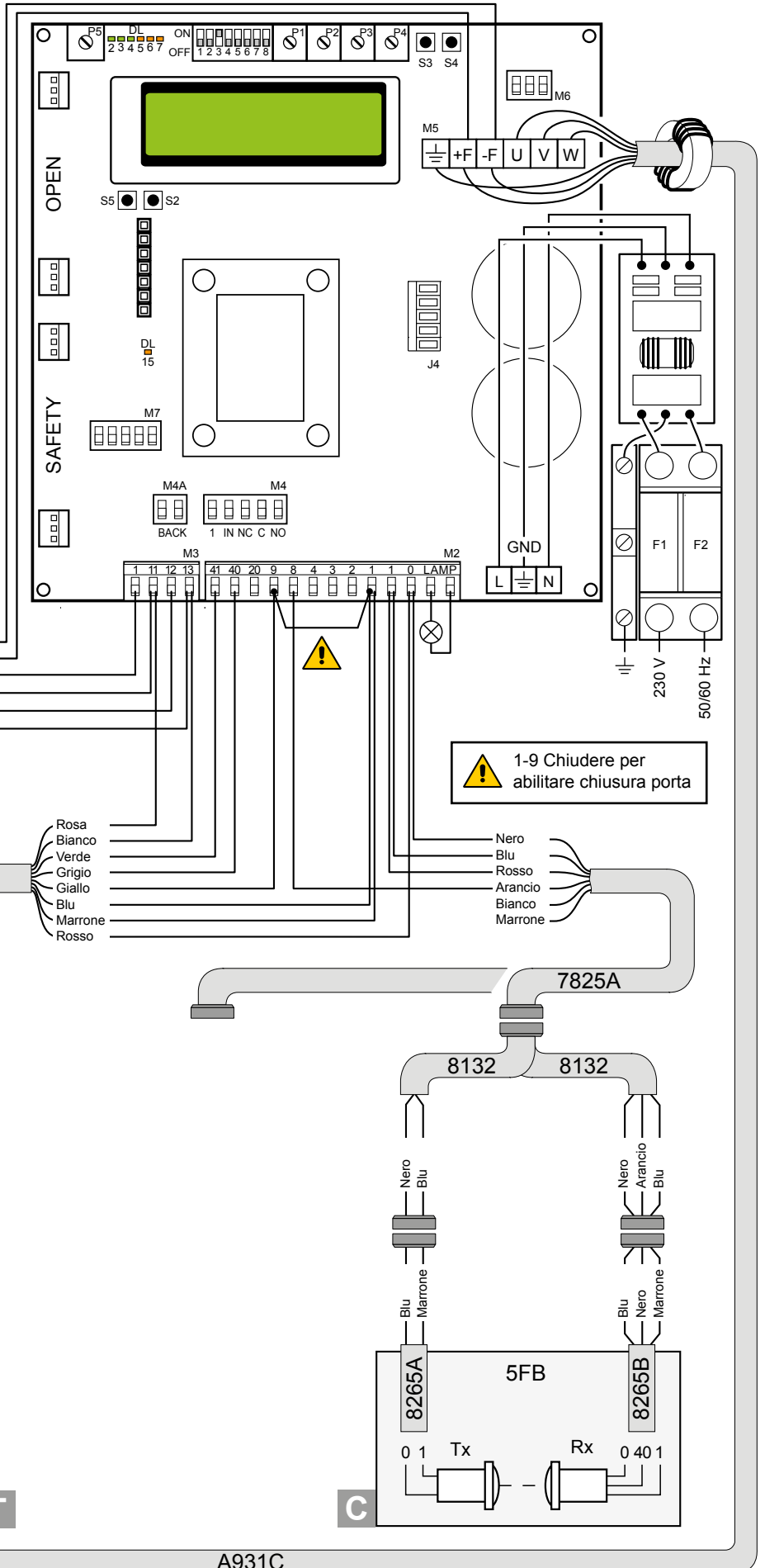
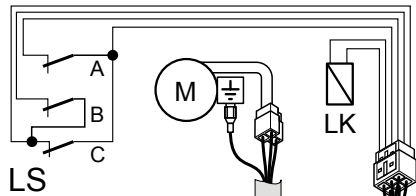
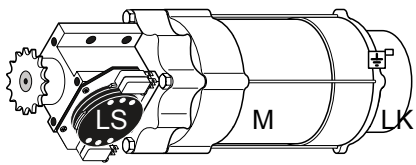

**A933A**  
 Bianco  
 Rosso  
 Blu  
 Nero  
 Marrone  
 Arancio

**8457**  
 Rosa  
 Bianco  
 Verde  
 Grigio  
 Giallo  
 Blu  
 Marrone  
 Rosso

Nero  
 Blu  
 Rosso  
 Arancio  
 Bianco  
 Marrone

Rosso  
 Blu  
 Giallo  
 Verde  
 Rosa  
 Bianco  
 Marrone  
 Grigio

0 1 9 41 FC FA OUT

**7825A**

**8132 8132**

Nero Blu  
 Nero Arancio Blu

Blu Marrone  
 Blu Nero Marrone

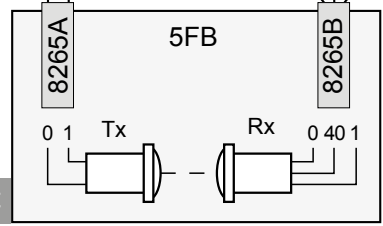

**! Dip 1 OFF  
 Dip 2,3,4 ON**

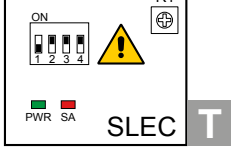

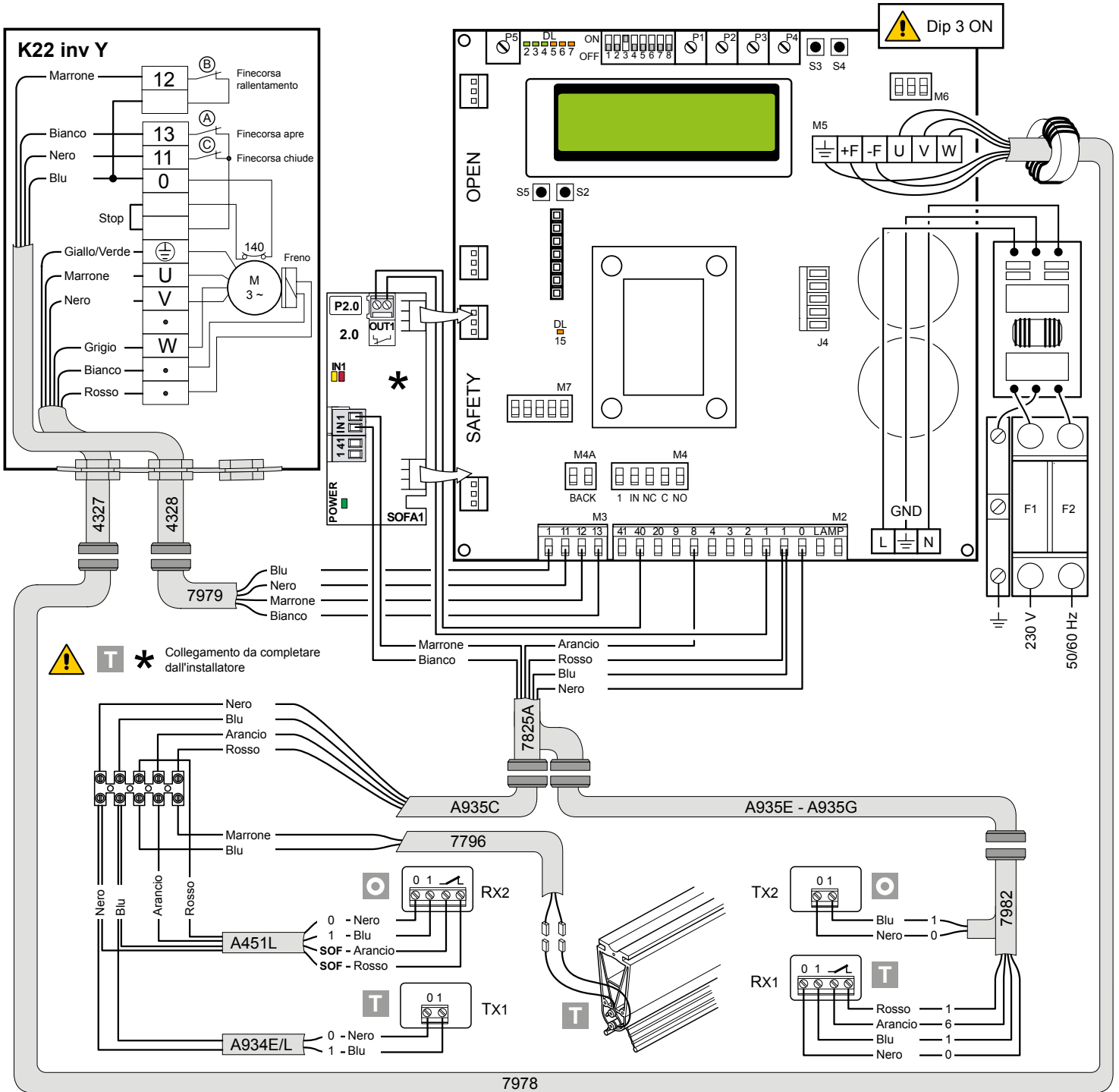

7978

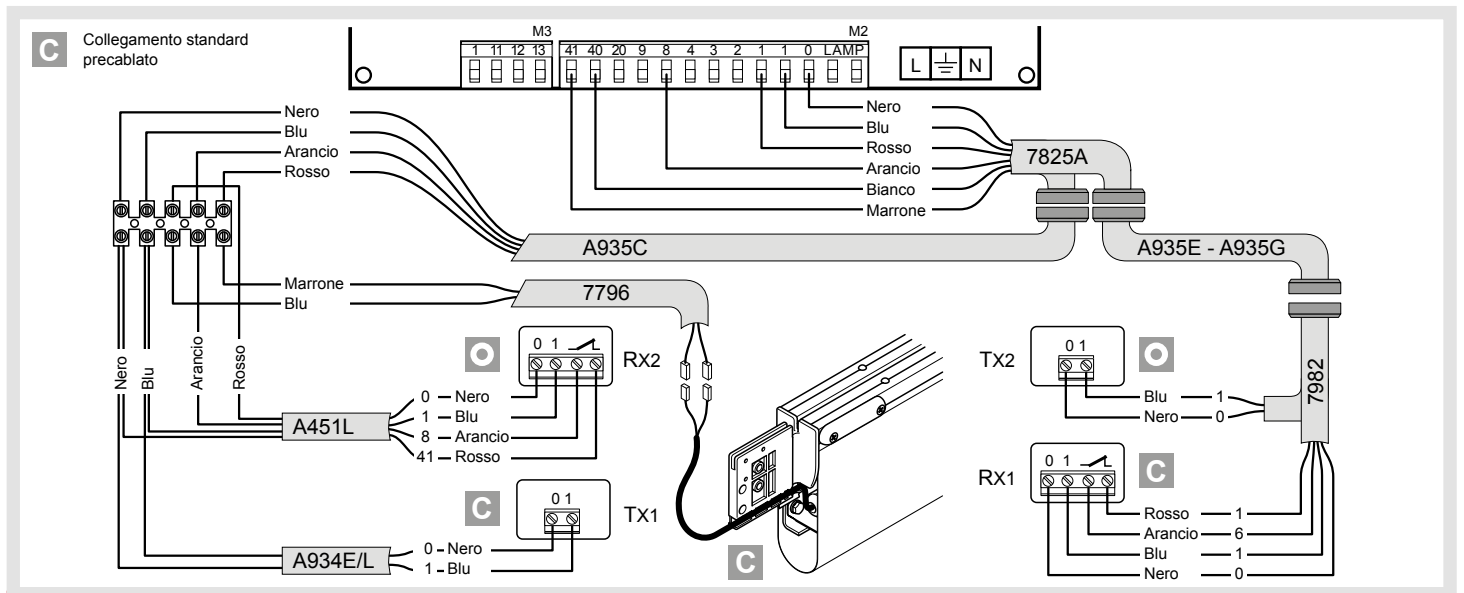

# SECTOR PLUS

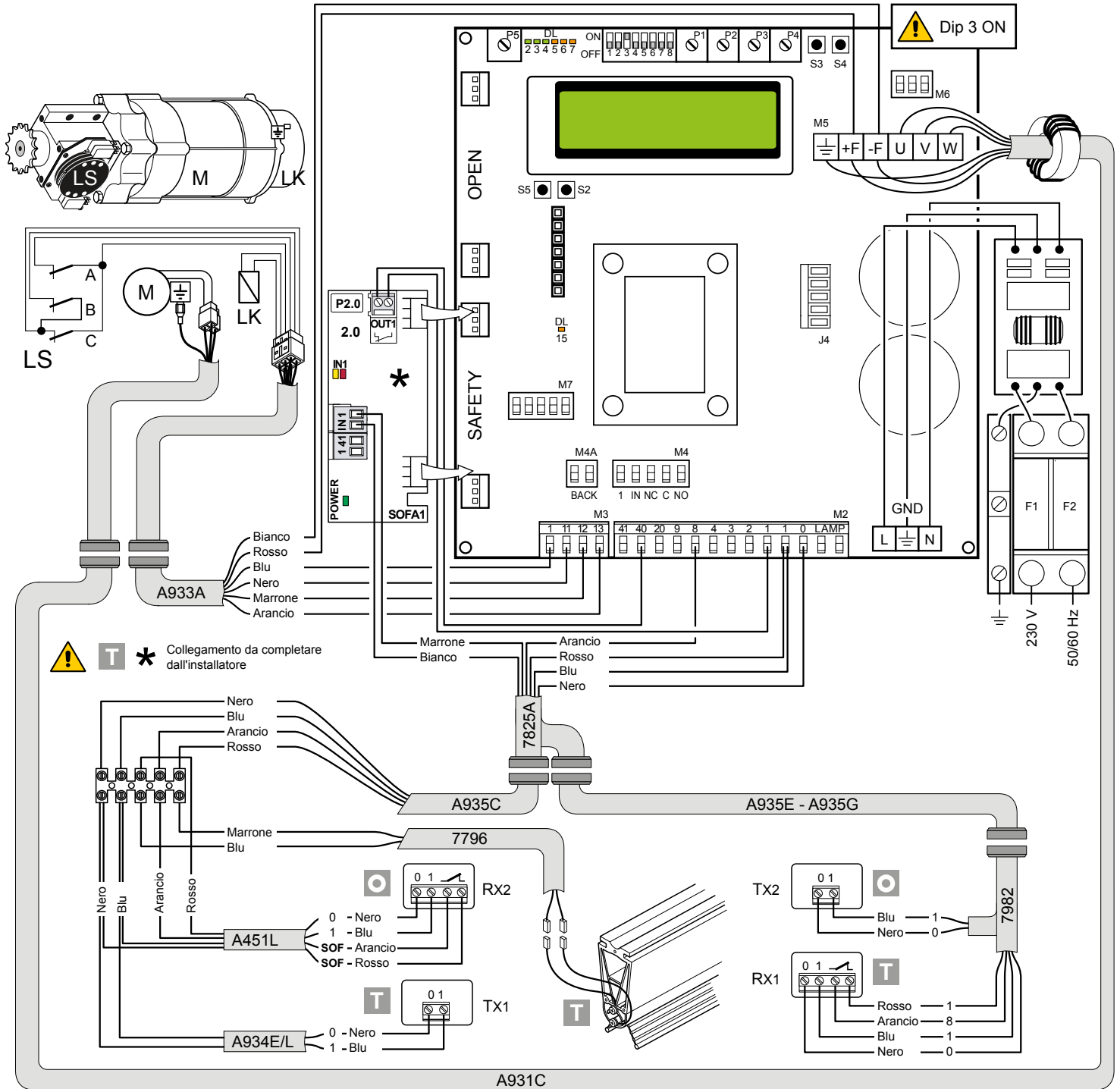

**C** Collegamento standard precablato

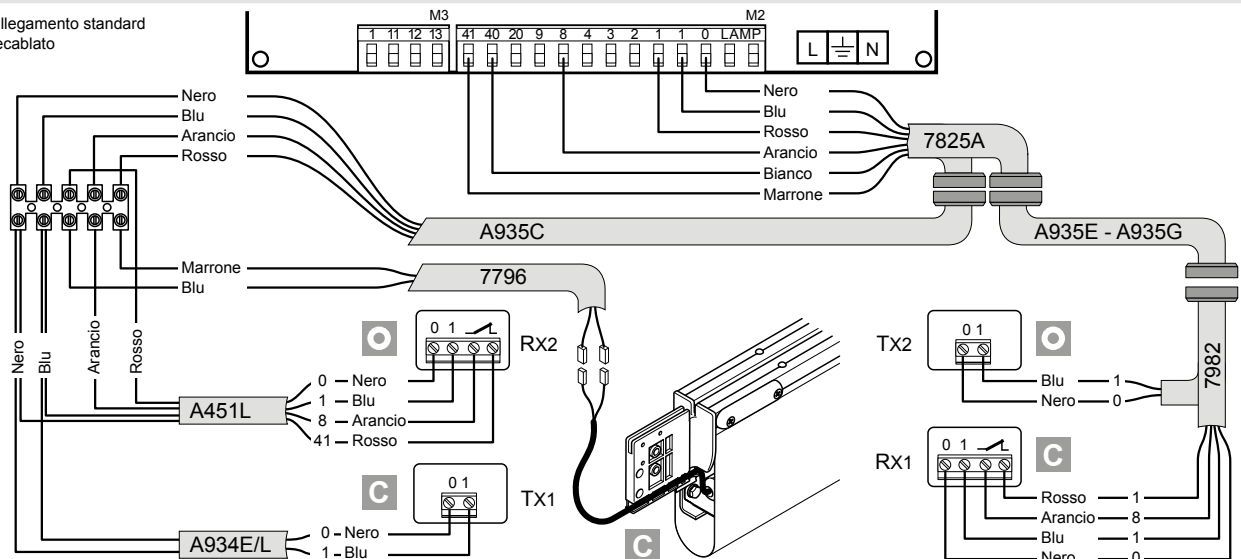



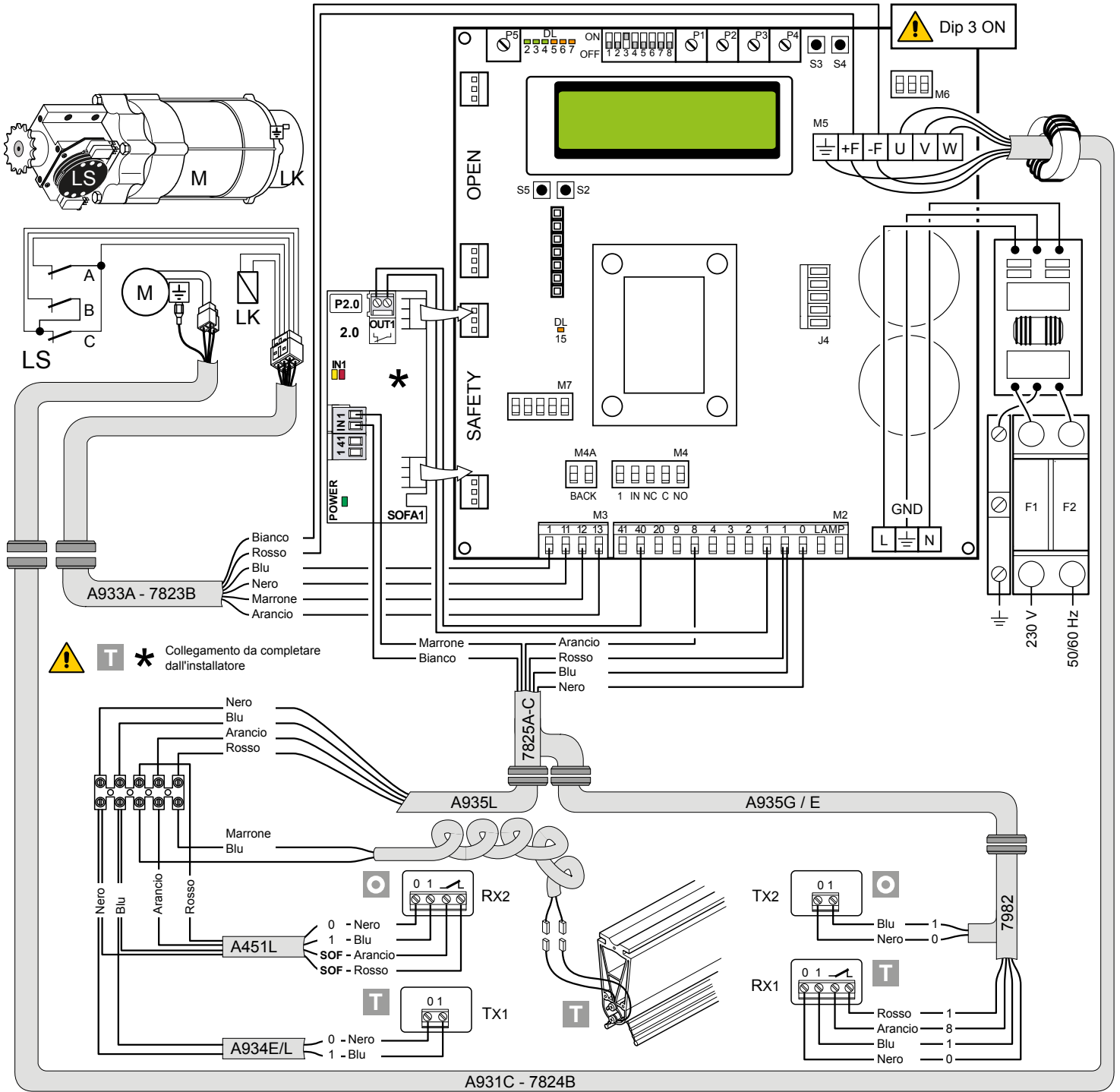

**!** **T** \* Collegamento da completare dall'installatore

A931C - 7824B

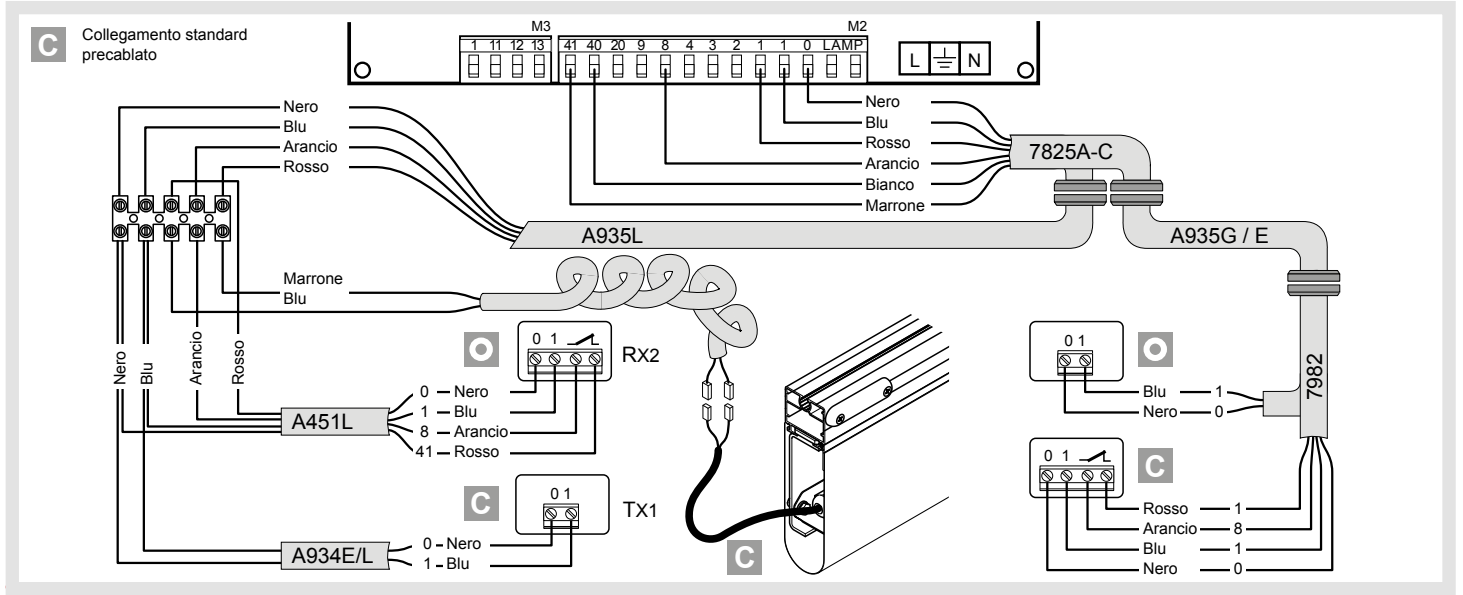

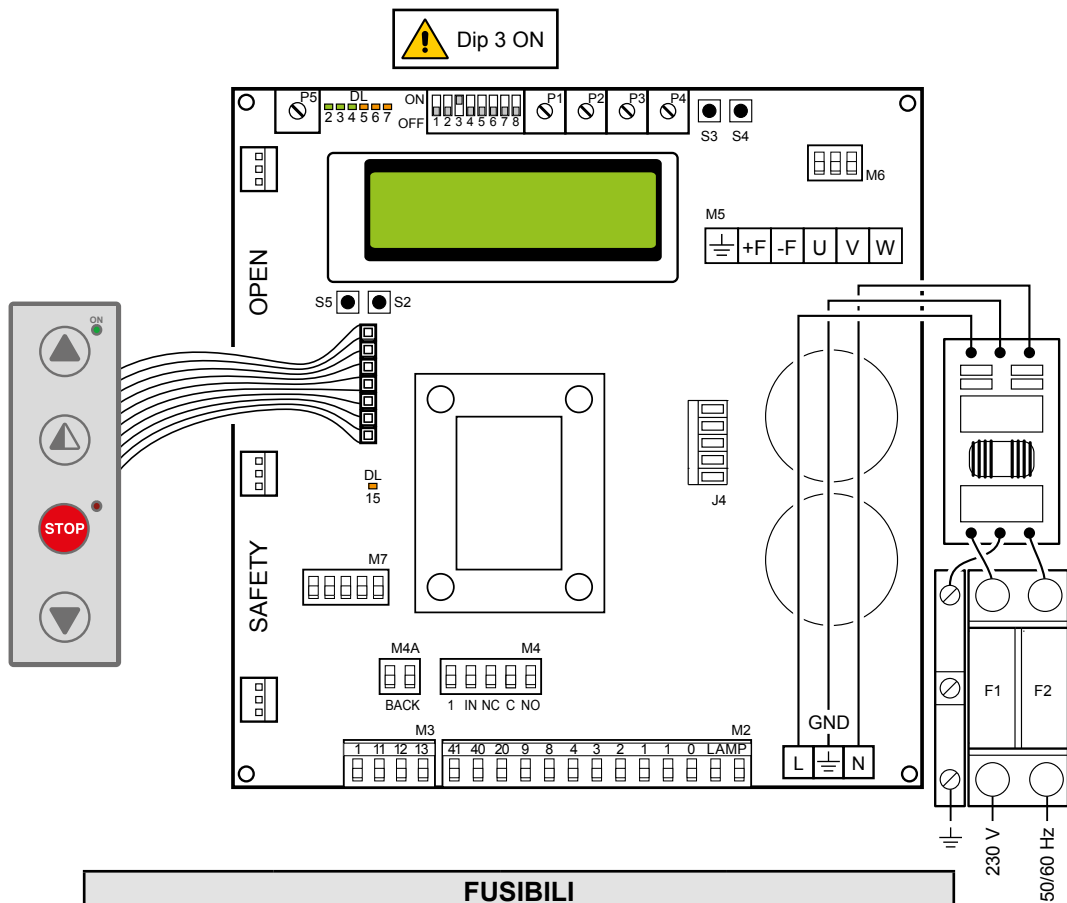

FUSIBILI			
ID	Valori	Dimensione	Circuito
F1 - F2	12A - 500V	10.3 x 38	Linea Monofase

#### 4. REGOLAZIONE FINECORSA

1. Tarare le rampe di decelerazione a zero. (P3 - P4)
2. Tarare il finecorsa (C) sul motoriduttore, in modo che la porta si fermi a circa 200/300 mm dal punto di chiusura.
3. Tarare il finecorsa di apertura (A), al punto di apertura.
4. Tarare il finecorsa di rallentamento (B) in modo che si impegni a circa  $\frac{3}{4}$  della corsa di apertura.
5. Tarare le velocità di apertura mediante trimmer (P1) e chiusura (P2).
6. Tarare i trimmer delle rampe di decelerazione (P3) apertura e (P4) chiusura, in modo da ottenere la fermata nelle posizioni effettive di porta aperta e chiusa.

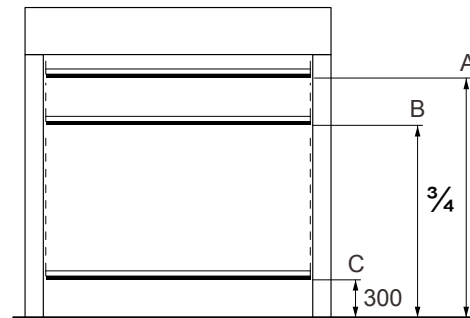
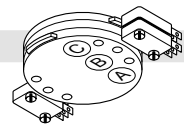























#### 5. RICERCA GUASTI

Messaggio display	Problema	Verifica
Supero limite corrente	Coppia motore richiesta maggiore di quella disponibile.	<ul style="list-style-type: none"> <li>• Diminuire velocità apertura.</li> <li>• Verificare alimentazione.</li> <li>• Verificare cablaggi alimentazione.</li> </ul>
Inserire resistenza di frenatura	Tensione sul BUS oltre la soglia	<ul style="list-style-type: none"> <li>• Per porte Sector Reset, collegare la resistenza di frenatura e impostare su "SI" la voce sul menù avanzato.</li> <li>• Spegner il quadro, attendere 3 minuti e ricollegare l'alimentazione.</li> <li>• Se l'errore riappare verificare che la tensione sul BUS sia inferiore a 360 V.</li> </ul>
Tensione BUS Max.	Tensione BUS oltre la soglia	<ul style="list-style-type: none"> <li>• Spegner il quadro, attendere 3 minuti e ricollegare l'alimentazione.</li> <li>• Verificare la tensione alimentazione quadro.</li> </ul>

## 6.1 MENU DI INSTALLAZIONE

All'accensione del quadro, il dispositivo dopo aver mostrato i messaggi DITECENTREMATIC e VERSIONE FW microprocessore e scheda entra automaticamente nel menù di installazione mostrando il messaggio SEL LINGUA.

Confermare con 

STEP	Scelte 1° livello	Scelte 2° livello	Scorrimento menu	Note
1	Sel. Lingua			Confermare con: 
	Confermare con: 	INGLESE	 	
		ITALIANO		
		FRANCESE		
		TEDESCO		
	SPAGNOLO			
2	Modello porta			Confermare con: 
	Confermare con: 	SRN300	 	
		SMART PLUS		
		SMART RESET		
		SECTOR PLUS		
		SECTOR RESET		
		TRAFFIC C		
	ALIMAX			
3	Gestione Posizioni			Confermare L'opzione Finecorsa con: 
	Confermare con: 	FINECORSA	 	
	ENCODER			
4	Taratura posizioni			La porta si muoverà fino alla posizione desiderata in modalità uomo presente e a bassa velocità.
	Confermare con: 	POSIZIONE CHIUDE	 	Confermare posizione Finecorsa dopo settaggio. 
		POS. APERTURA PARZIALE (indica posizione inizio rallentamento)		
	POSIZIONE APRE			
5	Modo comando			Confermare con: 
	Confermare con: 	IMPULSIVO	 	
	UOMO PRESENTE			
6	CONFERMA DATI			Confermare con: 

## PROGRAMMAZIONE EFFETTUATA

La porta a questo punto risulta programmata e funzionante (con chiusura automatica e comando impulsivo) con i valori di velocità impostati di default.

Con porta IN MOVIMENTO, verranno visualizzati su display i valori di tensione e corrente sul BUS.

## 6.2 MENU AVANZATO

Il menù avanzato permette la modifica della posizione dei finecorsa precedentemente settati e la possibilità di modificare i parametri impostati di default.













































Per accedere al Menù Avanzato:





















- **Mettere la porta in STOP**
- **Settare il DIP 2 in ON**



Sul display apparirà "TARAT. FINEC.", prima voce del menù avanzato.

 **TERMINATA LA PROGRAMMAZIONE RIPORTARE IL DIP2 IN OFF**

STEP	Scelte 1° livello		Scelte 2° livello		Note
1	Taratura Finecorsa	per Scorrimento  o  per Confermare 	Posizione chiude	 	Permette di visualizzare la posizione del telo in corrispondenza dei settaggi finecorsa.
2	Tempo apertura parziale	per Scorrimento  o  per Confermare 	VARIANTE TEMPO	 	Tempo di default 2,5 sec.
3	Chiusura automatica (default SI con T= 5 s)	per Scorrimento  o  per Confermare 	SI NO	 	
4	Tempo Chiusura Automatica	per Scorrimento  o  per Confermare 	Variante tempo	 	Opzione disponibile solo se al punto 4) è stato scelto SI. Valore variabile da 0 a 100sec.
5	Modo comando	per Scorrimento  o  per Confermare 	Impulsivo Uomo Presente	 	
6	Sicurezza in apertura	per Scorrimento  o  per Confermare 	SI NO	 	Se impostato SI, la porta chiusa che riceve un comando di apertura, non apre se la fotocellula è impegnata.
7	Interblocco	per Scorrimento  o  per Confermare 	NO INTERBLOCCO AIRLOCK INTERLOCK	 	<u>AIRLOCK</u> : porta 2 apre con comando esterno solo se porta 1 è chiusa. <u>INTERLOCK</u> : porta 2 apre automaticamente dopo chiusura porta 1
8	Prelampeggio apertura (default no)	per Scorrimento  o  per Confermare 	SI NO	 	Il pre-lampeggio ha un tempo fisso di 3 sec.
9	Abilitaz. Allarmi service	per Scorrimento  o  per Confermare 	SI NO	 	

10	Soglia service	per Scorrimento  o  per Confermare 	VARIARE VALORE	 	Opzione disponibile solo se al punto 14) è stato scelto SI. Impostare valore a Step di 1000 cicli. Max 200.000 cicli
11	Abilitazione stop 1-2	per Scorrimento  o  per Confermare 	SI NO	 	Se impostato SI, quando l'apertura del contatto 1-2 implica lo STOP della porta.
12	Resistenza di frenatura (default NO)	per Scorrimento  o  per Confermare 	SI NO	 	Impostare SI quando la porta viene fornita con resistenza di frenatura.
13	RESET PARAMETRI	per Scorrimento  o  per Confermare 	CONFERMI	 	Confermando si torna al menù installazione.

### 6.3 Menù Service (richiede password)

Il menù Service permette la modifica delle soglie della resistenza di frenatura, della soglia della sovracorrente

Per accedere al Menù Service:

- Mettere la porta in STOP
- Settare il DIP5 in ON
- Inserire la PW: sequenza pulsanti APRE - APRE - CHIUDE - APERTURA PARZIALE

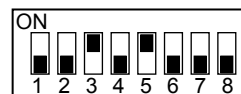

STEP	Scelte 1° livello	Note
1	V FREN. MIN (Minima tensione di bus) Default 340Vdc	Se la tensione di BUS scende sotto questo valore, viene chiesta la verifica della linea di alimentazione quadro (sezione filo adatto per supportare corrente assorbita). Un abbassamento della tensione di bus comporta un aumento della corrente di bus). Variabile da 300V a 350V
2	V FREN. MAX (Regolazione soglia intervento resistenza di frenatura) Default 380Vdc	Valore sopra il quale viene richiesto l'inserimento della resistenza di frenatura. Variabile da 355V a 400V
3	LIMITE SOVRACORRENTE Default 10A	Se corrente su BUS supera la soglia impostata, la porta apre ad una velocità dimezzata per diminuire l'assorbimento.
4	ELENCO ALLARMI	Vengono visualizzati gli ultimi 50 allarmi: Sovracorrente; tensione bus fuori limite, Intervento resistenza frenatura, sovratempertaura inverter, fault driver motore (encoder). Per uscire premere apertura parziale.



**TERMINATA LA PROGRAMMAZIONE RIPORTARE IL DIP5 IN OFF**

## 7. ALLARMI

MESSAGGIO	SITUAZIONE	NOTE
Ditec Entrematic	porta chiusa in attesa di comando	
Apertura vbus iBUS	porta in movimento di apertura	
Porta aperta - tempo chiusura automatica	porta aperta	
Chiusura vbus iBUS	porta in movimento di chiusura	
Input 40 chiuso ; input 8 aperto	intervento fotocellula	Durante movimento porta
Input 40 aperto ; input 8 chiuso	intervento sicurezza primaria (SLEC / COSTA)	Durante movimento porta
Finecorsa aperti	Intervento micro di sicurezza su dispositivo di apertura manuale / intervento protezione termica motore / finecorsa apertura (A) e chiusura (C) contemporaneamente attivi.	
Sicurezza apre attiva	fotocellula ingaggiata a porta chiusa e porta che non apre	Messaggio che appare solo se su menù avanzato (step 7) la funzione "sicurezza di apertura" è settato Sì.
Porta in stop	comando di stop attivo	

## 8. INTERBLOCCO

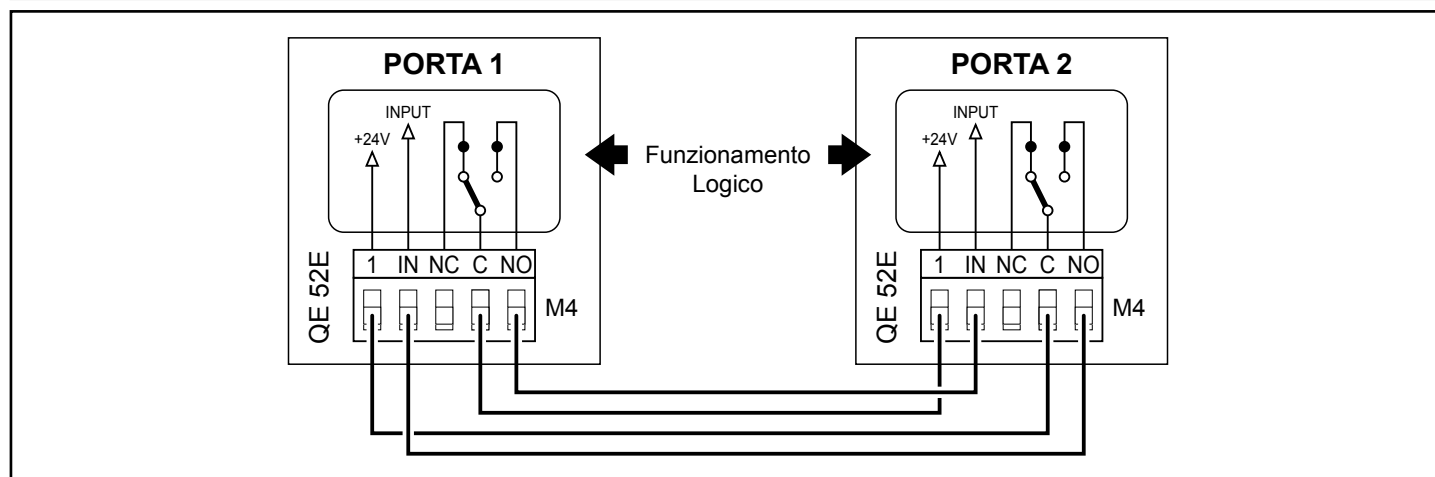

**CONTENTS**

Ch.	Topic .....	Page
1.	<b>CONNECTIONS</b> .....	16
2.	<b>ADJUSTMENTS AND SETTINGS</b> .....	17
3.	<b>ELECTRICAL CONNECTIONS</b>	
	Smart Reset .....	18
	Sector Reset .....	19
	Smart Plus .....	20
	Sector Plus .....	21
	Traffic C .....	22
4.	<b>LIMIT SWITCH ADJUSTMENT</b> .....	23
5.	<b>TROUBLESHOOTING</b> .....	23
6.	<b>PROGRAMMING</b>	
	Installation menu .....	24
	Advanced menu .....	25
	Service menu .....	26
7.	<b>ALARMS</b> .....	27
8.	<b>INTERLOCK</b> .....	27

**1. GENERAL SAFETY PRECAUTIONS**

This installation manual is intended for professionally competent personnel only. Installation, electrical connections and adjustments must be performed in accordance with Good Working Methods and in compliance with the current standards.

Read the instructions carefully before installing the product. Incorrect installation could be dangerous. The packaging materials (plastic, polystyrene, etc.) should not be discarded in the environment or left within reach of children, as they are a potential source of danger.

Before installing the product, make sure it is in perfect condition. Do not install the product in explosive areas and atmospheres: the presence of inflammable gas or fumes represents a serious safety hazard. Before installing the door, make all the structural modifications necessary in order to create safety clearance and to guard or isolate all the crushing, shearing, trapping and general danger areas.

Make sure the existing structure is up to standard in terms of strength and stability. The safety devices (photocells, safety edges, emergency stops, etc.) must be installed taking into account current laws and directives, Good Working Methods, the installation environment, the system operating logic and the forces developed by the motorised door or gate.

The safety devices must protect any crushing, shearing, trapping and general hazardous areas of the door. Display the signs required by law to identify hazardous areas.

Each installation must clearly indicate the door identification data.

Before connecting the power supply, make sure the plate data correspond to those of the mains power supply. An omnipolar disconnection switch with a contact opening distance of at least 3mm must be fitted on the mains supply.

Check there is an adequate residual current circuit breaker and overcurrent cutout upstream of the electrical system. Connect the door to an efficient earthing system that complies with current safety standards. The door manufacturer declines all responsibility if components not compatible with safety and good functioning are installed, or modifications of any kind are made that have not been specifically authorised by the manufacturer. Use only original Entrematic Group AB spare parts when repairing or replacing products. The installer must supply all information concerning the automatic, manual and emergency operation of the motorised door or gate, and must provide the user with the operating instructions.

**Optional accessory**





**Comfort Safety**

**Top Safety**

**All rights reserved**

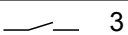
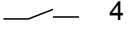
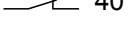
The data given have been compiled and checked with the greatest care. We cannot, however, assume any responsibility for any errors, omissions or approximations due to technical or graphical requirements.

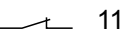
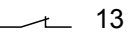
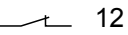
## 52E 1. 52E CONTROL PANEL (INVERTER) - Connections





INPUTS				
Command		Function	Description	
1		2 NC	STOP	If on the programming menu (page 15 point 16) With contact 1-2 enabled, the opening of the contact STOPS the door
1		3 NO	Opening	The closure of the contact activates the opening operation.
1		4 NO	Closure	The closure of the contact activates the closing operation.
41		40 NC	Reversal safety contact	The opening of the safety contact triggers a reversal of the movement (reopening) during the closing operation.
1		8 NC	Reversal safety contact	The opening of the safety contact triggers a reversal of the movement (reopening) during the closing operation.
1		20 NO	Partial opening	The closure of the contact activates a partial opening operation of the duration set with the advanced menu.
1		11 NC	Closing limit switch	The opening of the contact stops the closing operation.
1		13 NC	Opening limit switch	The opening of the contact stops the opening operation.
1		12 NC	Deceleration limit switch	The opening of the contact activates deceleration during opening.
1		9 NO	Closure enabling with SLEC	In the case of doors with SLEC, the opening of the contact allows the door to work only when someone is present.

### CONTROL PANEL CONNECTORS



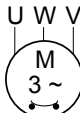

M2	Safety device / Commands
M3	Position signal
M4	Interlock
M4A	Back
M5	Motor / brake motor

J4	Brake resistance
OPEN	Auxiliary panel card
SAFETY	Auxiliary safety card

### OUTPUTS

Output	Value	Description
1  + 0  -	24V = / 0.5A	<b>Power supply to accessories.</b> Power supply output for external accessories, including automation status lamps.
 LAMP	230V~ / 50W	<b>Flashing light (LAMP).</b> Activated during opening and closing operations.
-F  +F	200V= / 0.2A or 24V = / 0.5A	<b>Electric motor brake.</b> Automatically set with the choice of door model in the programming menu. The output is active for the duration of both the opening and closing operations.
	230V~ / 6A	<b>Three-phase motor.</b>







Trimmer	Description
P1 	Opening speed
P2 	Closing speed
P3 	Deceleration during opening
P4 	Adjustment of deceleration during closure
P5 	Adjustment of display contrast.

Dip-switches	Description	OFF	ON
DIP 1	Future use	–	–
DIP 2	Access to advanced menu	Disabled	Enabled
DIP 3	Trimmer enabling	Disabled	Enabled
DIP 4	<b>Counter</b> TOT: Number of operations SVC: Number of operations left until service	Disabled	Enabled
DIP 5	Access to service menu	Disabled	Enabled
DIP 6	<b>Door operating data display</b> (F working, I Bus, I peak, V Bus)	Disabled	Enabled
DIP 7	Future use	–	–
DIP 8	Future use	–	–

LED	On
DL2	Closing position
DL3	Deceleration
DL6	Partial opening
DL7	Opening position
DL15	Autostart

Buttons	Description
S2	USED FOR PROGRAMMING
S3	NOT USED
S4	NOT USED
S5	USED FOR PROGRAMMING

	Operating mode		Programming Operating
	Standard	LED	
Button	LED	Button	
 Starts the opening operation.	- The green LED on indicates the presence of the 24 V= power supply.	Menu scrolling	
 Starts the partial opening operation.		Confirm	
 Starts and stops the STOP operation.	- The red LED on indicates that the STOP has been activated. - The flashing red LED indicates that the safety devices have been activated. - The quick flashing red LED indicates that the service threshold has been reached		
 Starts the closing operation.		Menu scrolling	

# SMART RESET

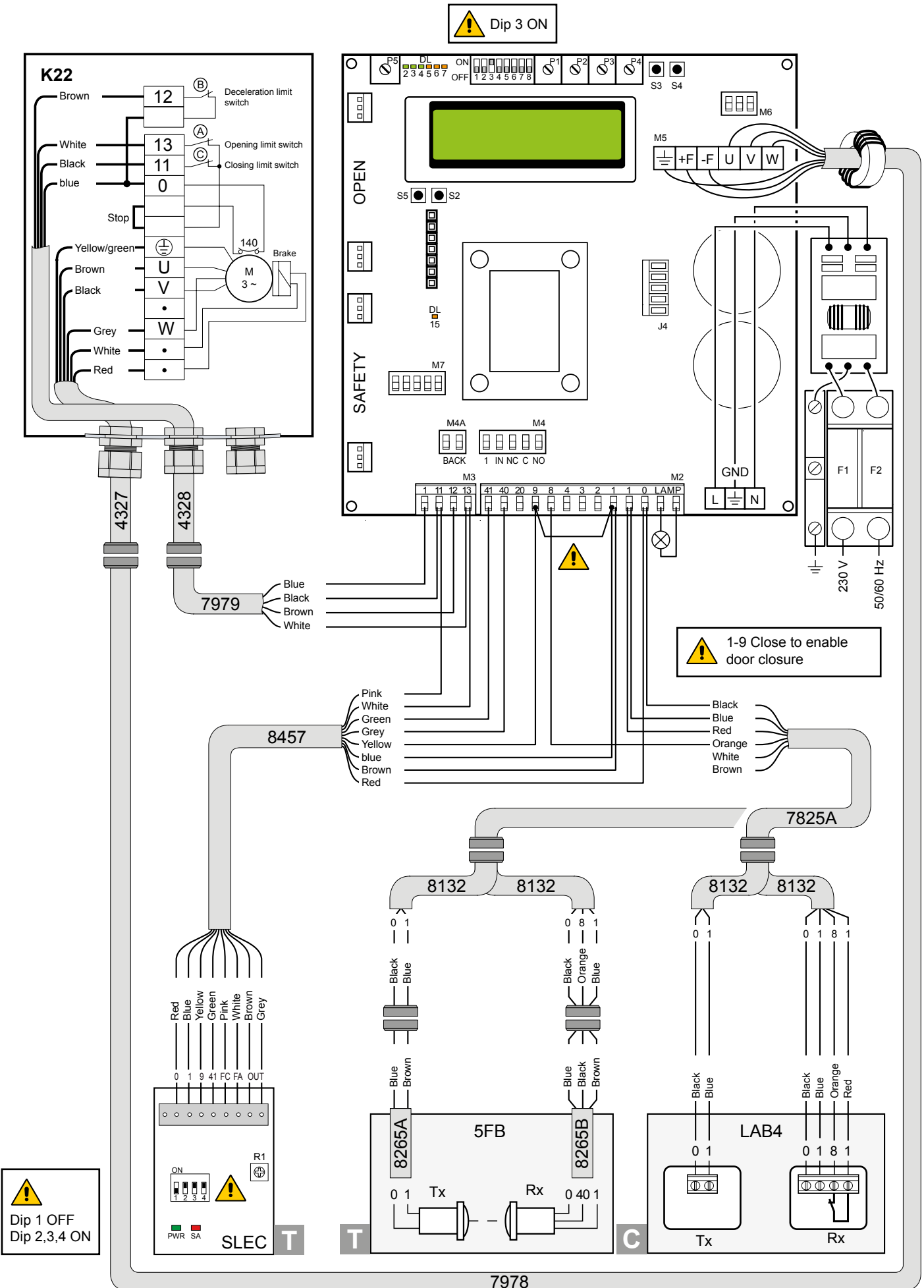

 Dip 3 ON

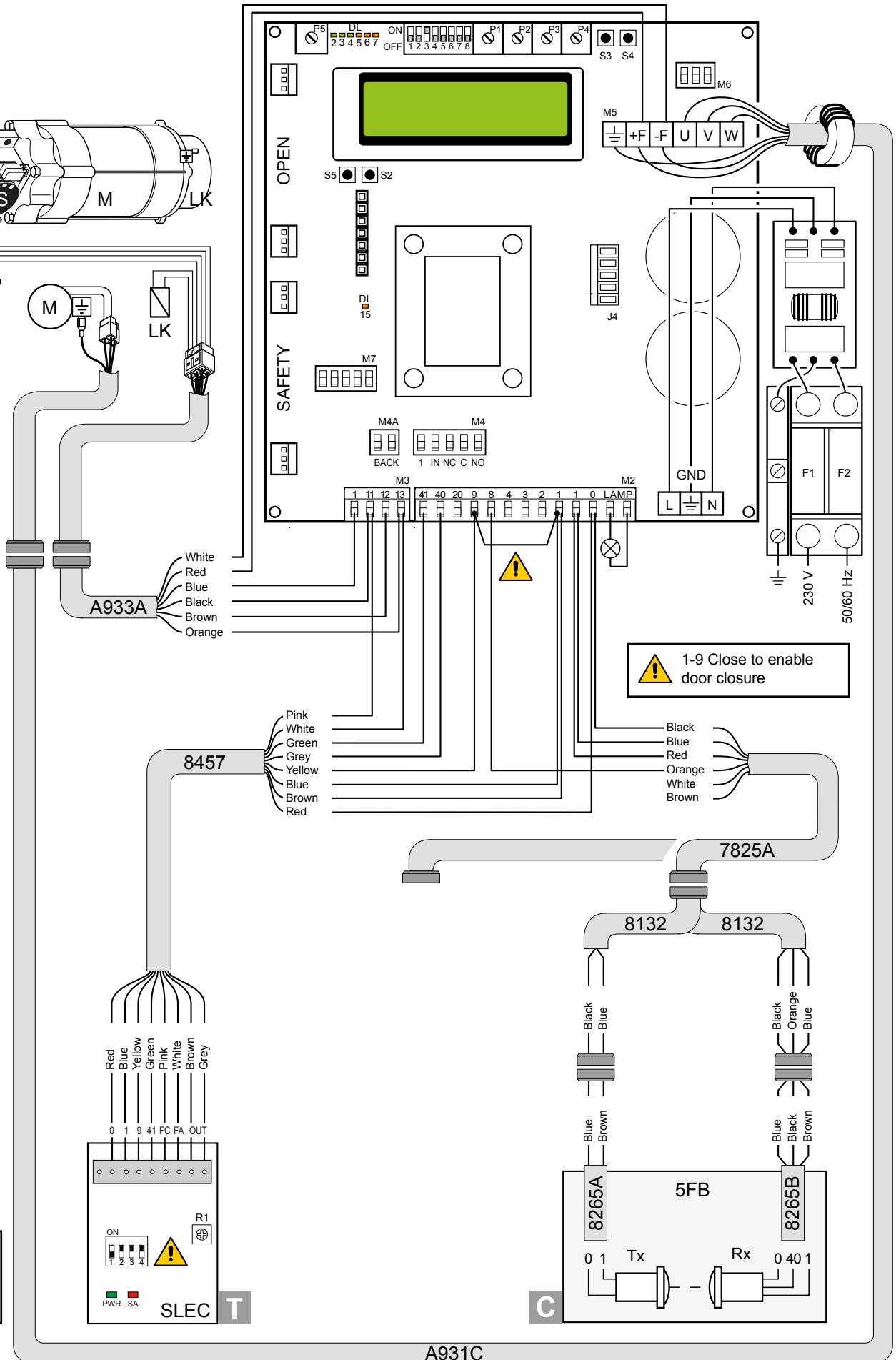
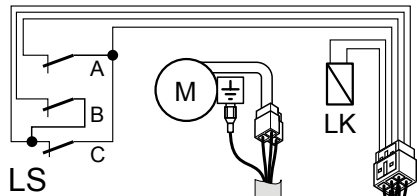
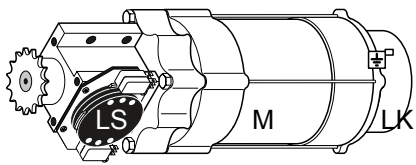

 Dip 1 OFF  
Dip 2,3,4 ON

# SMART PLUS

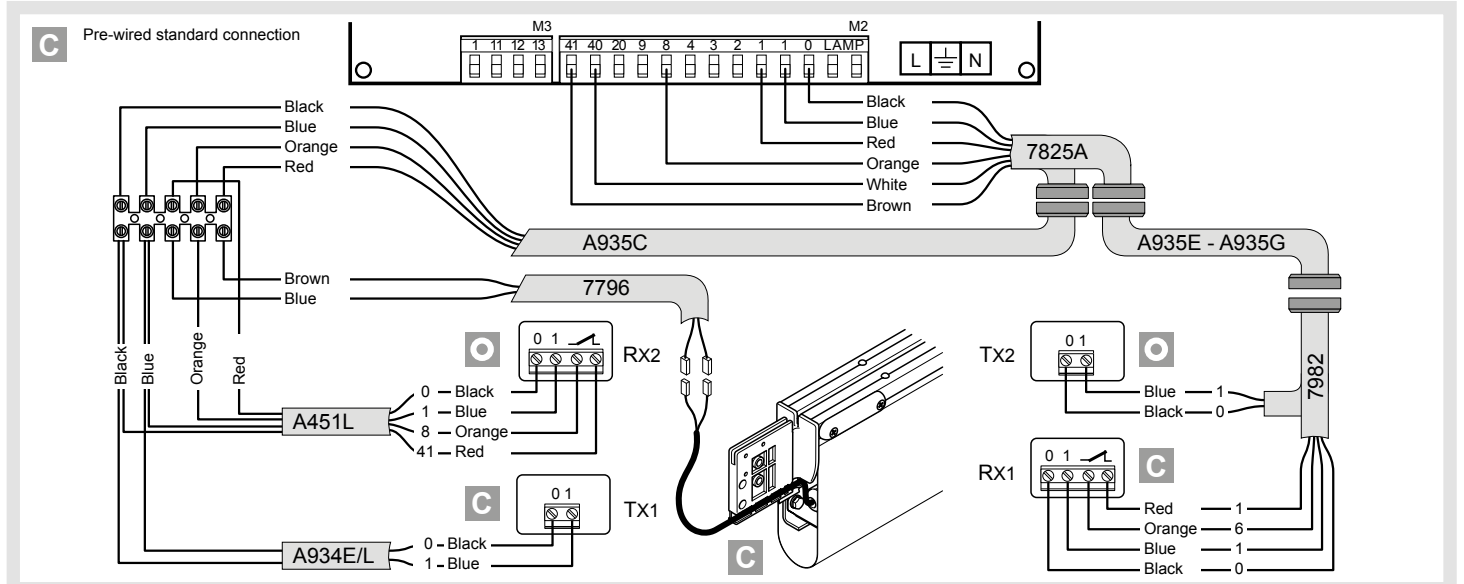
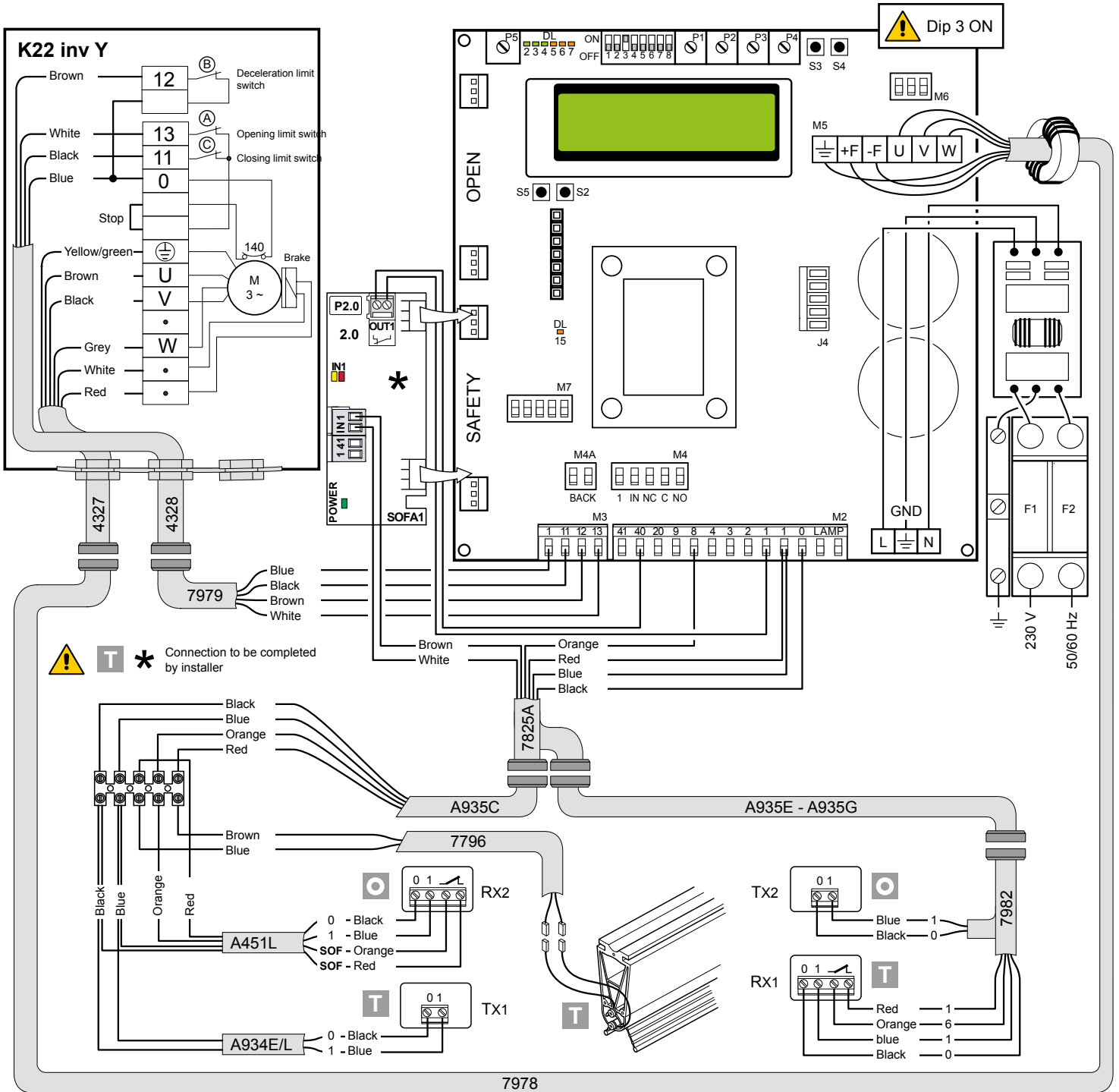

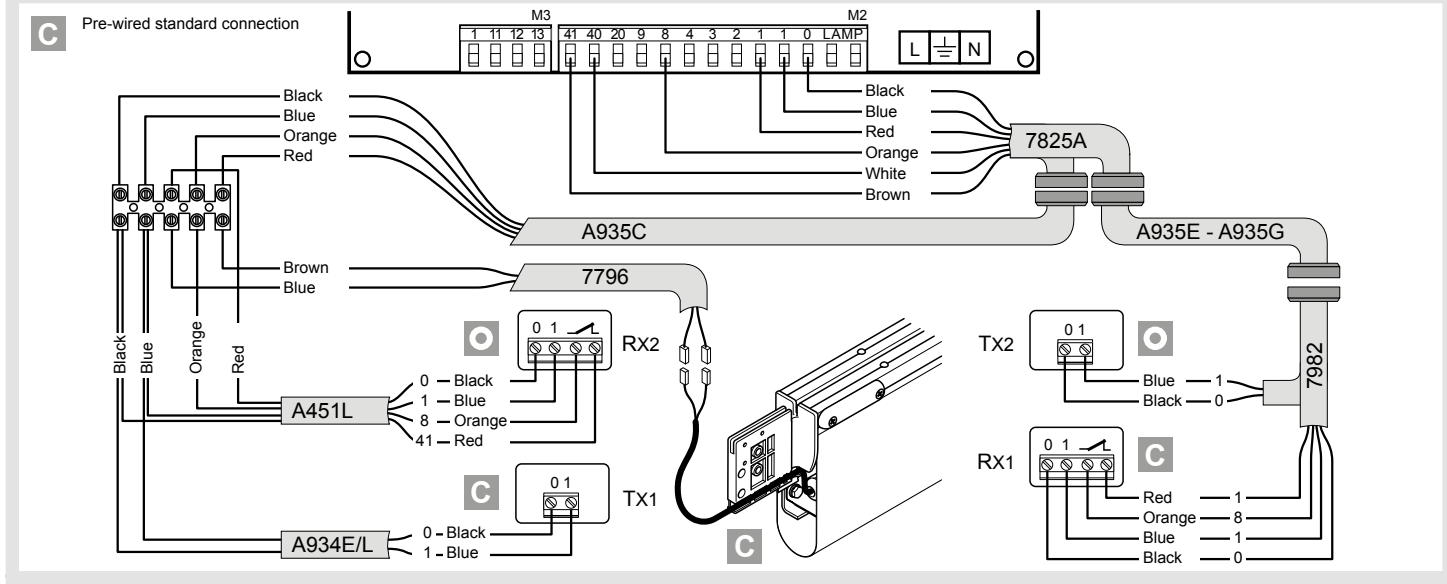
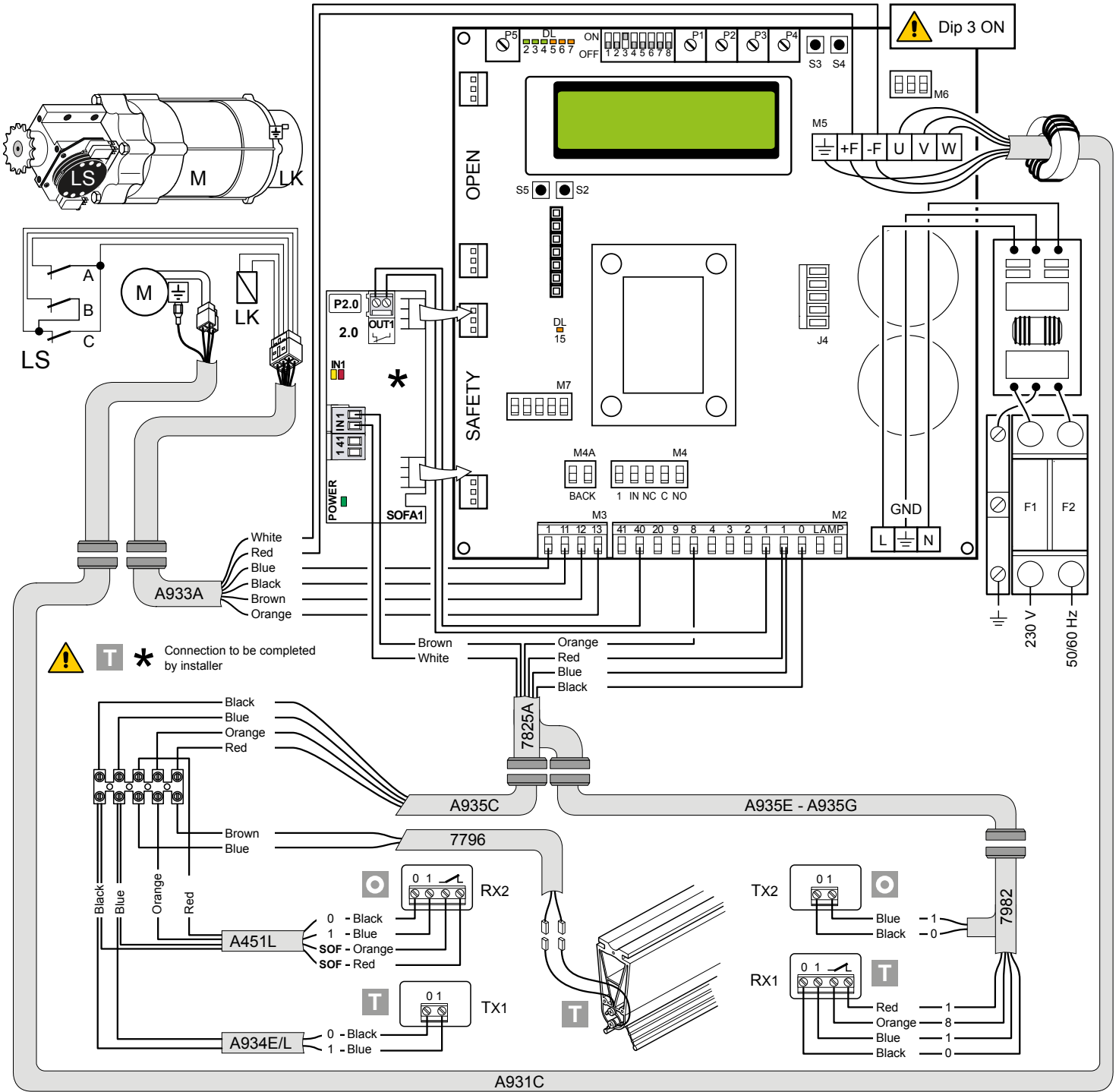

# TRAFFIC C

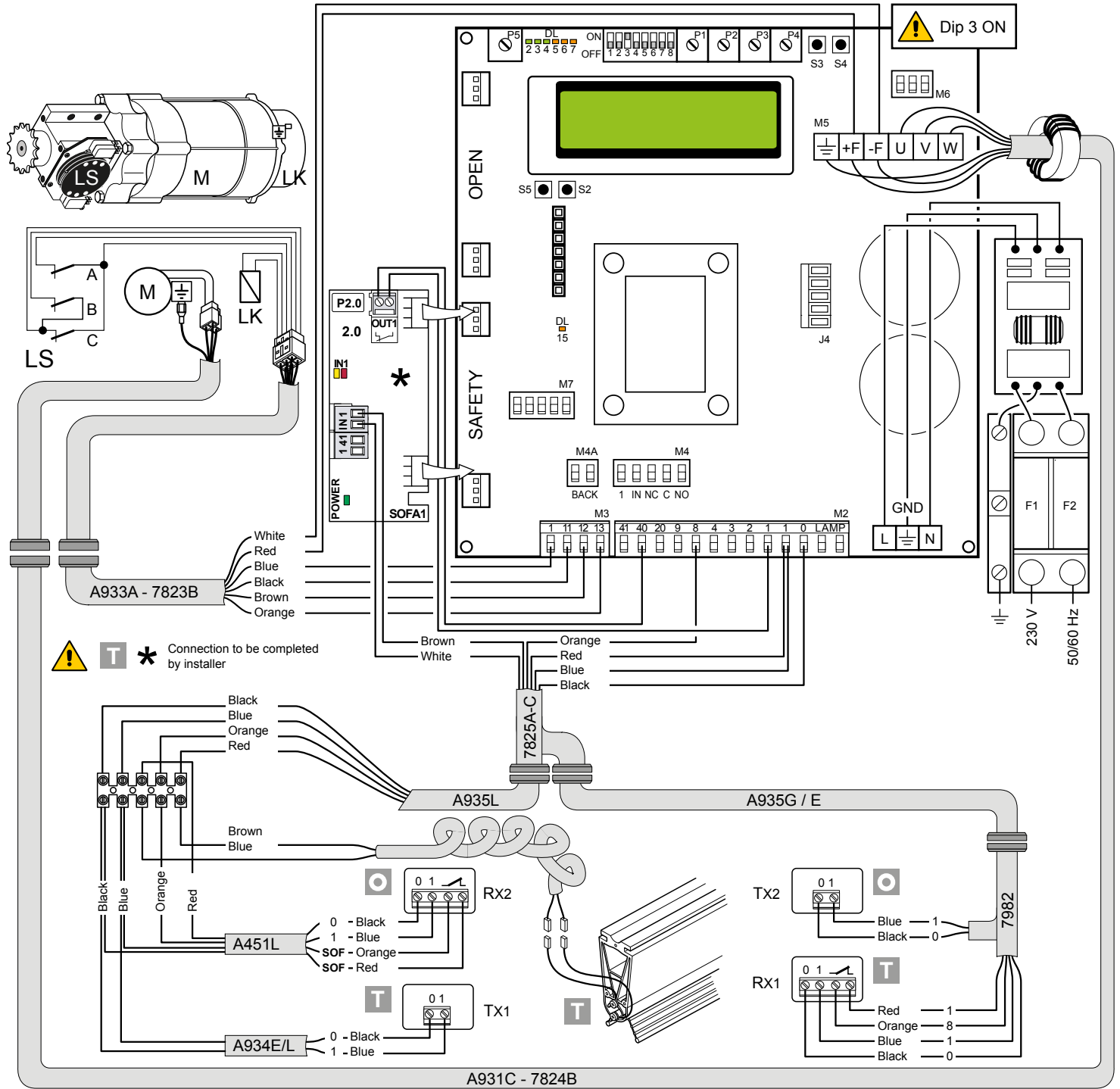

A931C - 7824B

**C** Pre-wired standard connection

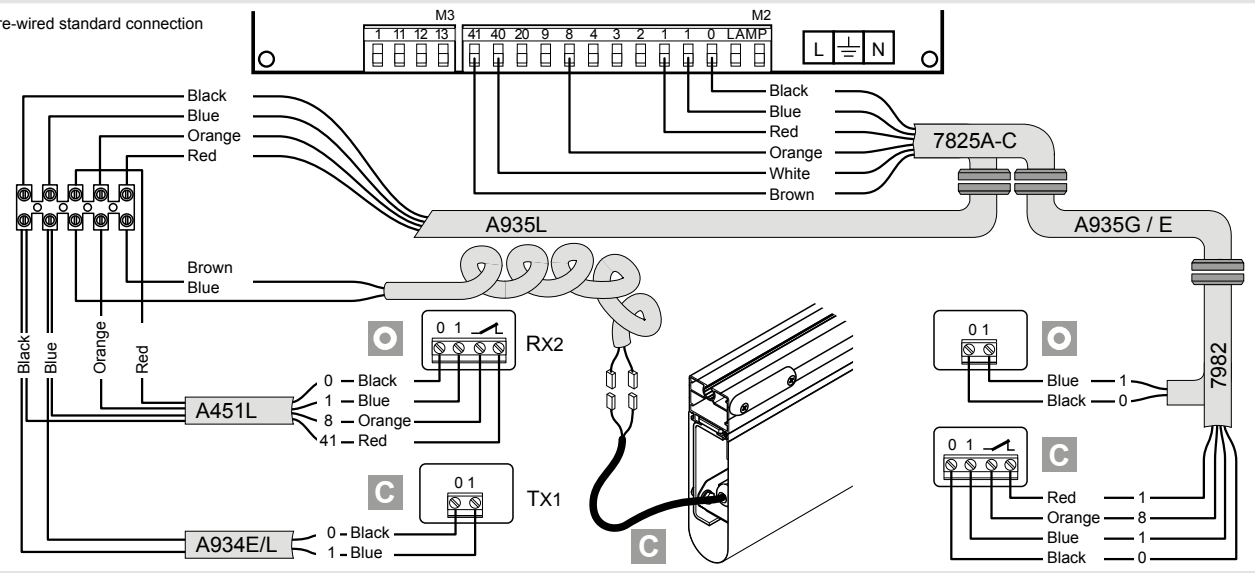

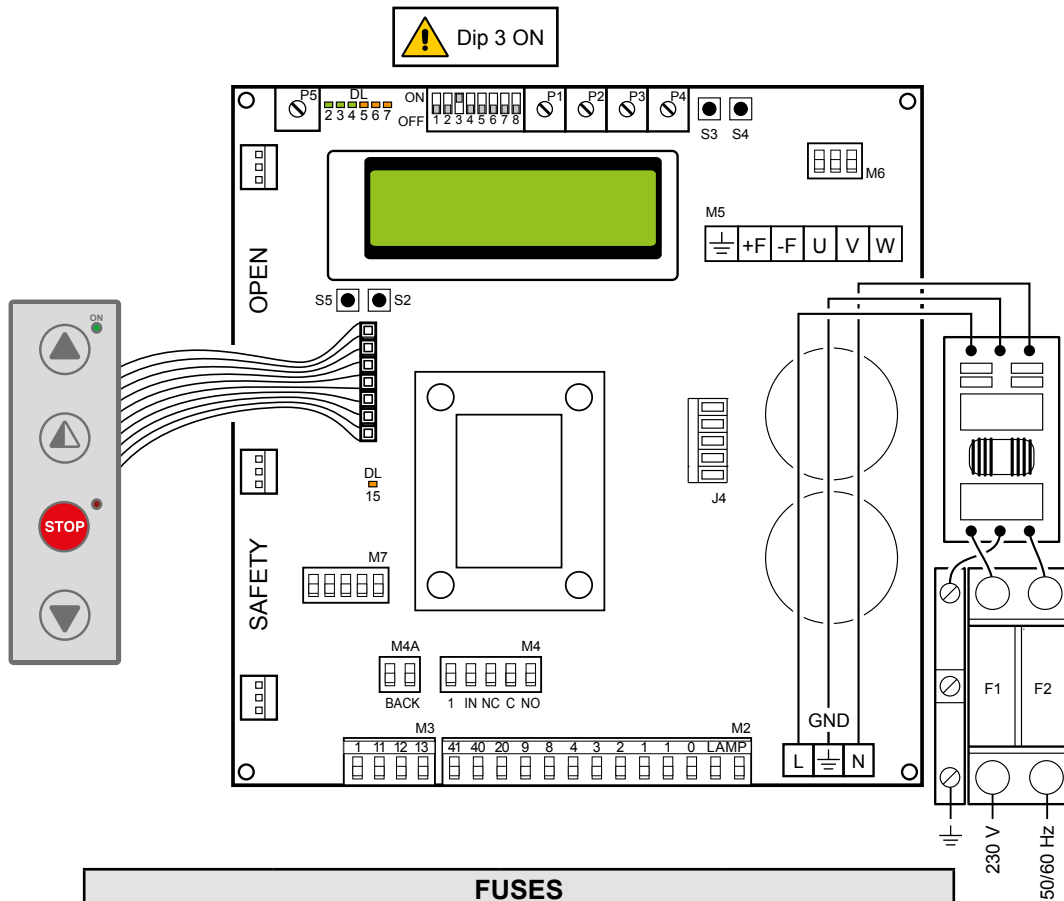

FUSES			
ID	Value	Size	Circuit
F1 - F2	12A - 500V	10.3 x 38	Single phase line

#### 4. LIMIT SWITCH ADJUSTMENT

1. Set the deceleration ramps at zero (P3 - P4)
2. Set the limit switch (C) on the gearmotor so that the door stops about 200/300mm from its closure point.
3. Set the opening limit switch (A) at the opening point.
4. Set the deceleration limit switch (B) so it is triggered at about  $\frac{3}{4}$  of the opening stroke.
5. Set the opening and closure speeds using trimmers (P1) and (P2) respectively.
6. Set the trimmers of the deceleration ramps - (P3) for opening and (P4) for closure - to ensure the door stops at its actual "open" and "closed" positions.

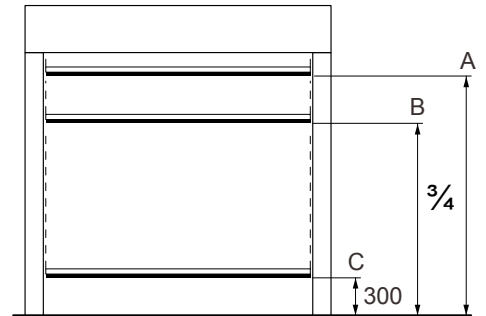
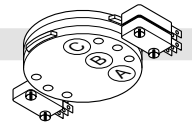

#### 5. TROUBLESHOOTING





















Display message	Problem	Check
Current limit exceeded	Requested motor torque exceeds available torque.	<ul style="list-style-type: none"> <li>• Reduce opening speed.</li> <li>• Check power supply.</li> <li>• Check power supply wiring.</li> </ul>
Insert brake resistance	Voltage on BUS exceeds threshold	<ul style="list-style-type: none"> <li>• For Sector Reset doors, connect the brake resistance and set the item on the advanced menu to "YES".</li> <li>• Switch off the control panel, wait 3 minutes and reconnect the power supply.</li> <li>• If the error reoccurs, check that the voltage on the BUS is lower than 360 V.</li> </ul>
Max. BUS voltage	BUS voltage exceeds threshold	<ul style="list-style-type: none"> <li>• Switch off the control panel, wait 3 minutes and reconnect the power supply.</li> <li>• Check the control panel power supply voltage.</li> </ul>

## 6. PROGRAMMING

### 6.1 INSTALLATION MENU

When the control panel is switched on, after showing the messages DITEC ENTREMATIC and microprocessor and card FW VERSION, the device automatically enters the installation menu and displays the message SELECT LANGUAGE.

Confirm with 

STEP	1 <sup>st</sup> level options	2 <sup>nd</sup> level options	Menu scrolling	Notes
1	Select language			Confirm with: 
	Confirm with: 	ENGLISH	 	
		ITALIAN		
		FRENCH		
		GERMAN		
	SPANISH			
2	Door model			Confirm with: 
	Confirm with: 	SRN300	 	
		SMART PLUS		
		SMART RESET		
		SECTOR PLUS		
		SECTOR RESET		
		TRAFFIC C		
	ALIMAX			
3	Position control			Confirm the Limit Switch option with: 
	Confirm with: 	LIMIT SWITCH	 	
	ENCODER			
4	Calibrating positions			The door will move to the required position in operator present mode and at low speed.  Confirm the Limit Switch position after setting 
	Confirm with: 	CLOSED POSITION	 	
		PARTIAL POSITION (indicates the deceleration start position)		
	OPEN POSITION			
5	Command mode			Confirm with: 
	Confirm with: 	IMPULSIVE	 	
	DEAD MAN			
6	CONFIRM DATA			Confirm with: 

### PROGRAMMING COMPLETED

The door is now programmed and operating (with automatic closure and pulse command) with the set default speed values. With the door MOVING, the voltage and current values will be displayed on the BUS.



## 6.2 ADVANCED MENU

The advanced menu allows you to modify the position of the limit switches which have previously been set and modify the set default parameters.

To access the Advanced Menu:



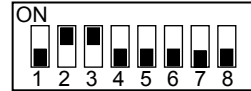

















- **STOP the door**
- **Set DIP 2 to ON**



“LIM. SWITCH CAL.”, the first item in the advanced menu, will appear on the display.

**! ONCE PROGRAMMING HAS ENDED, SET DIP2 TO OFF**

STEP	1 <sup>st</sup> level options		2 <sup>nd</sup> level options		Notes
1	Limit switch calibration	to scroll or to confirm 	Closed position		Used to view the position of the door section corresponding to the limit switch settings.
2	Partial opening time	to scroll or to confirm 	TIME VARIANT		Default time - 2.5 sec.
3	Automatic closure (default SI with T= 5 s)	to scroll or to confirm 	YES NO		
4	Automatic closing time	to scroll or to confirm 	Time variant		Option available only if YES has been selected for point 4). Value ranging from 0 to 100 sec.
5	Command mode	to scroll or to confirm 	Impulsive DEAD MAN		
6	Opening safety device	to scroll or to confirm 	YES NO		If set to YES, the closed door that receives an opening command does not open if the photocell is activated.
7	Interlock	to scroll or to confirm 	NO INTERLOCK AIRLOCK INTERLOCK		<u>AIRLOCK</u> : door 2 opens with external command only if door 1 is closed. <u>INTERLOCK</u> : door 2 opens automatically when door 1 has closed
8	Pre-flashing when opening (default no)	to scroll or to confirm 	YES NO		Pre-flashing has a set time of 3 sec.
9	Service alarm enabling	to scroll or to confirm 	YES NO		

10	Service thresh	 to scroll or  to confirm 	CHANGE VALUE	 	Option available only if YES has been selected for point 14). Set value to steps of 1000 cycles Max 200,000 cycles
11	Enable stop 1-2	 to scroll or  to confirm 	YES	 	If set to YES, opening of the contact 1-2 STOPS the door.
			NO		
12	Brake resistance (default NO)	 to scroll or  to confirm 	YES	 	Set to YES when the door is supplied with brake resistance.
			NO		
13	PARAMETER RESET	 to scroll or  to confirm 	CONFIRM	 	Confirm to go back to the installation menu.

### 6.3 Service menu (password required)

The Service menu is used to modify the brake resistance thresholds, the overcurrent threshold

To access the Service menu:

- STOP the door
- Set DIP5 to ON
- Enter the PW: button sequence OPEN- OPEN- CLOSE- PARTIAL OPENING

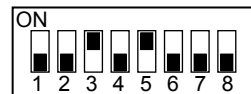

STEP	1 <sup>st</sup> level options	Notes
1	MIN BRAKING VOLT. (Minimum bus voltage) Default 340V DC	If the BUS voltage falls below this value, a check on the control panel power supply line is requested (wire section suitable for withstanding the absorbed current. When the bus voltage decreases, the bus current increases). Varies from 300V to 350V
2	MAX BRAKING VOLT. (Adjustment of brake resistance intervention threshold) Default 380V DC	Value above which insertion of brake resistance is required. Varies from 355V to 400V
3	OVERCURRENT LIMIT Default 10A	If the current on the BUS exceeds the set threshold, the door opens at half the speed to reduce absorption.
4	ALARM LIST	The last 50 alarms are displayed: Overcurrent; bus voltage exceeds limit, Intervention of brake resistance, inverter overtemperature, faulty motor driver (encoder). To exit, press partial opening



**ONCE PROGRAMMING HAS ENDED, SET DIP5 TO OFF**

7. ALARMS

MESSAGE	SITUATION	NOTES
Ditec Entrematic	door closed waiting for command	
Opening of VBUS IBUS	door opening	
Door open - automatic closing time	Door open	
Closing of VBUS IBUS	door closing	
Input 40 closed; input 8 open	intervention of photocell	When door is moving
input 40 open; input 8 closed	Primary safety device intervention (SLEC / SAFETY EDGE)	When door is moving
Limit switches open	Intervention of safety microswitch on manual opening device / intervention of thermal protection on motor / opening (A) and closure (C) limit switches simultaneously active.	
Opening safety device activated	photocell engaged when door is closed and door does not open	Message that only appears if the "safety in open" function is set to YES on the advanced menu (step 7).
Door stopped	stop command activated	

8. INTERLOCK

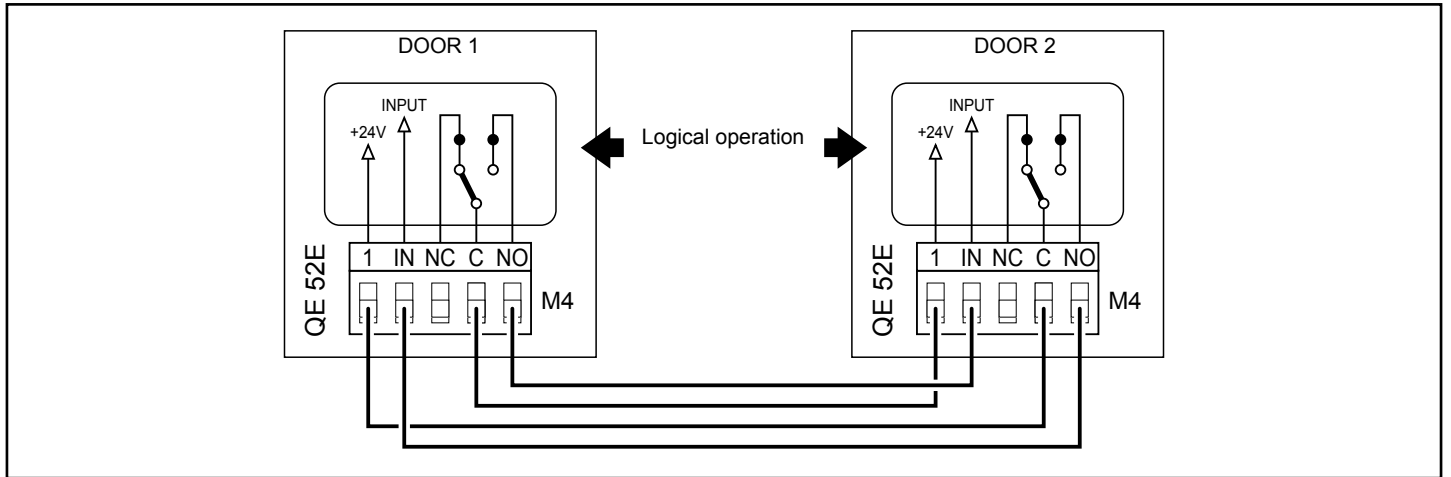

---

Entrematic Group AB  
Lodjursgatan 10  
SE-261 44, Landskrona  
Sweden  
[www.ditecentrematic.com](http://www.ditecentrematic.com)

**Ditec**  

---

**ENTRE//MATIC**

